

FKW18-12/24/40.5 Outdoor HV Load Break Switch

Summary

FKW18-12/24/40.5 outdoor AC high voltage load break switch is used in rated voltage 12/24/40.5kV, rated frequency 50/60Hz outdoor three-phase power system. The load break switch is composed of disconnect blade, arc extinguishing chamber and operation mechanism, simple structure, strong extinguishing arc ability, reliable performance, etc.

NOTE: The model of the 12kV (vertical break) Outdoor HV Load Break Switch is FHY3-12.



Ambient condition

1. Altitude: $\leq 3000\text{m}$;
2. Ambient temperature: $-25^{\circ}\text{C} \sim +40^{\circ}\text{C}$;
3. Wind speed: $\leq 35\text{m/s}$;
4. Pollution degree: $\leq \text{IV}$;
5. Earthquake intensity: ≤ 8 degree;
6. Ice thickness: $\leq 10\text{mm}$.

Model

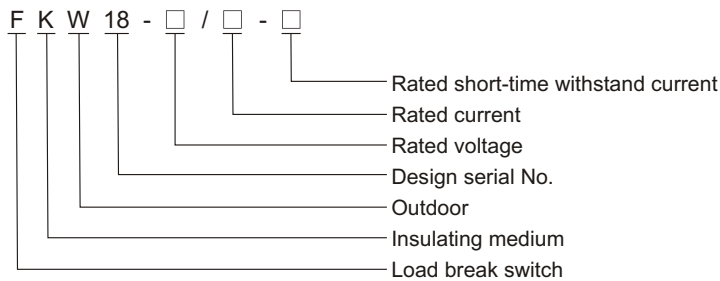

Technical specification

No.	Item		Unit	Data		
1	Rated voltage		kV	12	24	40.5
2	Rated current		A	630		
3	Rated power frequency		Hz	50/60		
4	Rated peak withstand current		kA	50		
5	Rated short-time withstand current		kA	20		
6	Rated short-circuit duration		s	4		
7	Rated active load breaking current		A	630		
8	Rated loop breaking current		A	630		
9	Rated cable charging current		A	10		
10	5% rated active load breaking current		A	31.5		
11	Rated power transformer breaking current		A	1250		
12	Rated short-circuit making current		kA	50		
13	Main loop resistance		$\mu\Omega$	≤ 90	≤ 95	≤ 95
14	1min power frequency withstand voltage	Dry	phase to phase, to earth	42	65	95
			across open contacts	49	79	115
15	Lightning impulse withstand voltage(peak)	Wet	phase to phase, to earth	30	63	85
			across open contacts	75	125	185
16	Mechanical life		Times	85	145	215
				2000		

17	Three phase O/C asynchronous	ms	≤5	
18	Voltage, power of motor	V W	≤220	≤200
19	Closing direction deflexion of blade	mm	≤2	
20	Main blade pressure	N	420 ± 42	
21	Rated operating moment	Nm	≤300	

Outline dimension

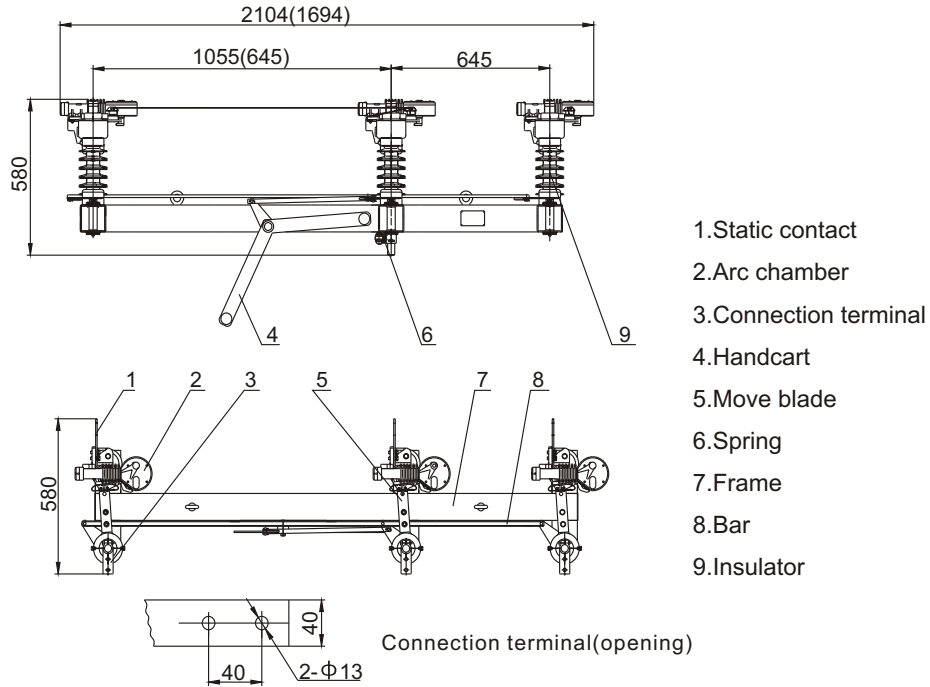

Drawing 1 12kV Switch structure (closing)

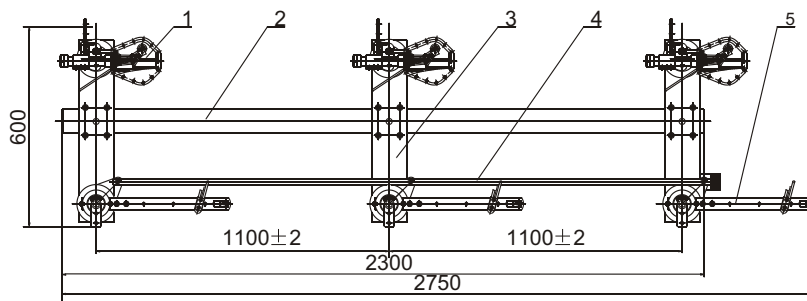

Left side view

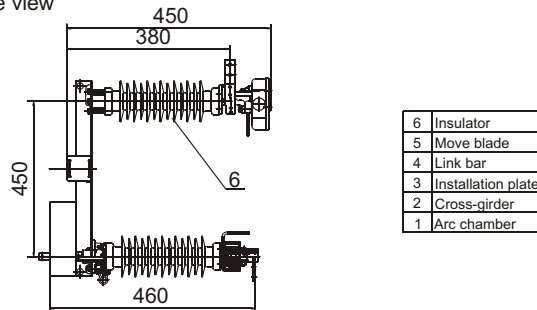

Drawing 2 24kV Switch structure

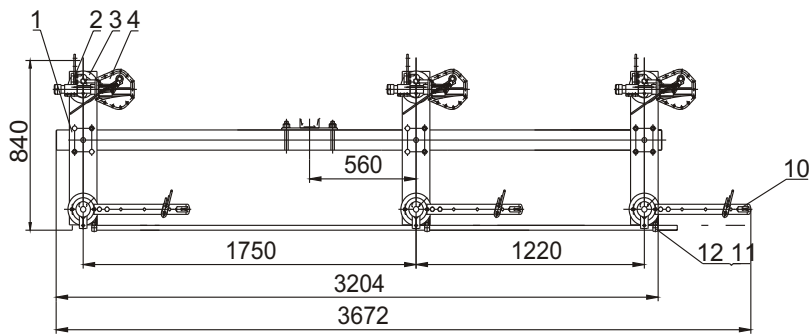

1. Frame
2. Static contact
3. Insulator
4. Arc chamber
5. Bushing
6. Connection terminal
7. Rotate bearing
8. Bushing
9. Bend-plate
10. Disconnect blade
11. Bar
12. Connection terminal
13. Spring

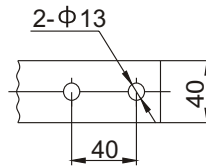
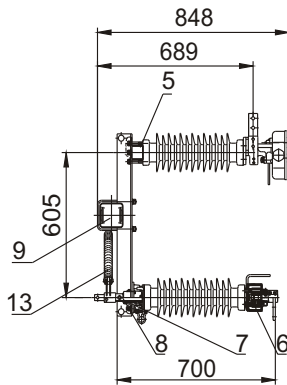

Connection terminal (opening)

Drawing 3 40.5kV Switch structure (closing)

Structure feature

FKW18-12/24/40.5 outdoor alternating current high voltage load break switch is composed of disconnect blade, arc extinguishing chamber and operating mechanism. Arc extinguishing chamber is made of insulating materials with merits of high electric performance, arc-endurance, high strength. Built-in linking spring with fast acting mechanism to ensure breaking of load current effecting free from operating speed, fast or slow. The arcing gap and disconnecting gap of the load breaker switch is parallel in the course of opening and closing, so the arcing gap is only used to extinguish arc, no task for carrier current, simplifying arcing structure; however the disconnect gap only takes on task for carrier current and short-circuit closing, not participating in extinguishing arc, so simple in structure and long in lifetime. In this way, the load break switch can be used as disconnect switch when don't consider the action of arcing gap, and with the action of arcing gap, the disconnect switch is changed into load break switch. This load break switch adopts manual linking rod or motor operating mechanism to operate, and to lock up location of opening & closing. There is visible gap of switch after opening to produce functions of isolating and protection. The LBS could be mounted on pole outdoor, could suit for pollution with IV degree, horizontal or vertical installation, very convenient for setting cables outdoor with few maintenance and arc extinguishing chamber breaking load without maintenance for 100 times. The A, B, C three-phase of the load breaker switch is in turn installed on one great sectional galvanized square steels base, joint together with one integrative drive axis inter-phase to ensure for closing & opening three poles synchronously. The blade of the switch uses press spring, to assure enough connection pressure to the contact, in this way, operation is convenient and the blade is stable, in the same time, the reliability of opening-closing operation is guaranteed. The switch opens or closes under rated load current, not requires connecting secondary protection device.

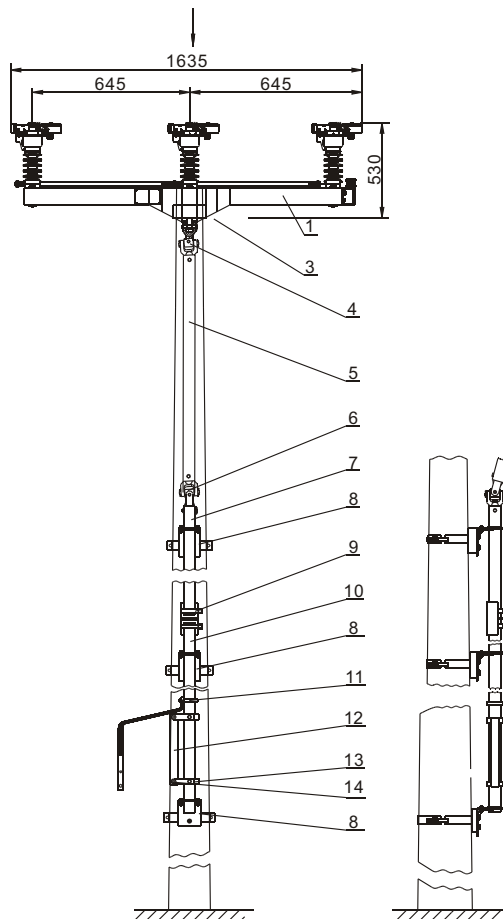

12kV horizontal installation

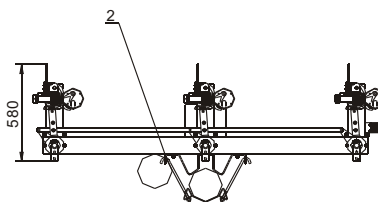

1. Switch assembly drawing
2. Switch bracket peices
3. Spring Mechanism(12kV)
4. Universal Knot
5. Linking Rod
6. Universal Knot
7. Linking Rod
8. Guiding bracket pieces
9. Jointing Pieces
10. Jointing Rod
11. Earthing Device
12. Operating Handle
13. Bracket
14. Lock

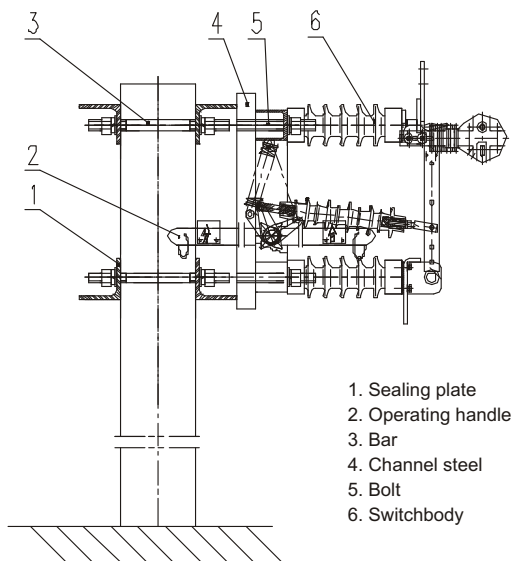

24kV vertical installation

Technical requirements

1. All ferrous parts should be finished with reliable anti-corrosion layer, smooth and no rust appearance.
2. Moving parts of driving mechanism should be added anti-freezing lubrication, neutral vaseline on moving & fixing contacts of live parts, and jointing nuts should be tighten where possible to loose.
3. Nameplate should be correct, clear, complete and easy to identify.
4. Outline dimension should be according to drawing requirements.
5. Mechanical operating test: Break & Close 50 times, should be no faults and should reach OFF & ON location each time.
6. Mechanical features test: Break asynchronism $\leq 5\text{ms}$, Close asynchronism $\leq 5\text{ms}$.
7. Main circuit resistance: $\leq 95\ \Omega$;
8. Between Phases and Phase to Ground: 90kV, 1Min. No puncture and flashover, between isolating gaps.
9. All according to relative technical requirements with OHY.502.603JT

1. Sealing plate
2. Operating handle
3. Bar
4. Channel steel
5. Bolt
6. Switchbody